

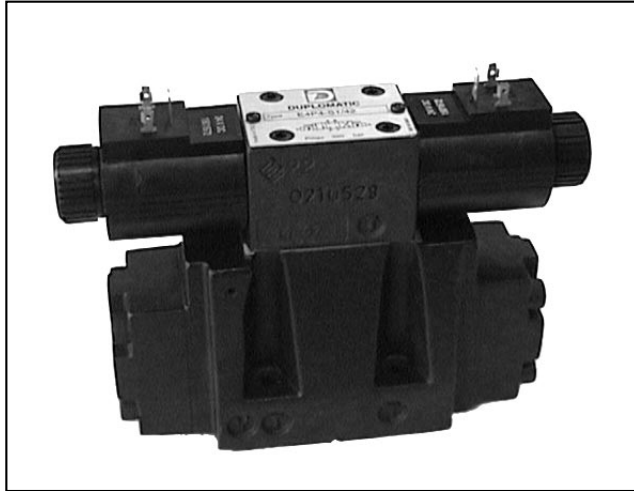

**DIPLOMATIC
HYDRAULICS**

41 400/101 ED



E*P4 PILOT OPERATED VALVES SOLENOID OR HYDRAULIC CONTROLLED

- E4 CETOP P05**
- E07 CETOP 07**
- E5 CETOP 08**
- E10 CETOP 10**

p max (see performance ratings table)

Q max (see performance ratings table)

- The E*P4 solenoid operated - hydropiloted valves are constituted of an MD1D type solenoid operated directional control valve that operates a 4-way hydropiloted control valve with a connection surface in accordance with the CETOP standards.
- They are made in four different sizes for maximum flow rates up to 1100 l/min.
- They are available in various configurations, centre types and connection diagrams.
- The piloting and the drainage can be made inside or outside the valve by inserting or removing the proper threaded plugs located in the main directional control valve (see par. 6).

A wide range of configurations and different solenoid operated - hydropiloted directional control valve spool positions at rest are available:

- Type S: 4-way, 3-position directional control valve, with two solenoids; positioning of spool at rest is obtained with centering springs.
- Type TA/TC: 4-way, 2-position directional control valve with 1 solenoid; positioning of the spool at rest is determined hydraulically by the pilot valve and mechanically (even without pressure) by the main stage return spring.
- Type RK: 4-way, 2-position directional valve, with two solenoids; with mechanical detent of the extreme pilot spool positions when solenoids are de-energized.

PERFORMANCE RATINGS (working with mineral oil of viscosity of 36 cSt at 50°C)		E4	E07	E5	E10	
Maximum operating - ports P A B (standard version) pressure: (H version) - port T (external drainage version)	bar		320 420 250		350 - 210	
	Maximum flow rate: - from port P to A-B-T	l/min	150	300	600	1100
	Ambient temperature range	°C	-20 ÷ +50			
Fluid temperature range	°C	-20 ÷ +70				
Fluid viscosity range	cSt	2.8 ÷ 380				
Recommended filtration	µm absolute	≤ 25				
Recommended viscosity	cSt	25				
Mass:	E*P4-S, RK	kg	8.6	9.1	15.6	45.0
	E*P4-TA/TC	kg	8.0	8.5	15	44,4



1 - IDENTIFICATION CODE

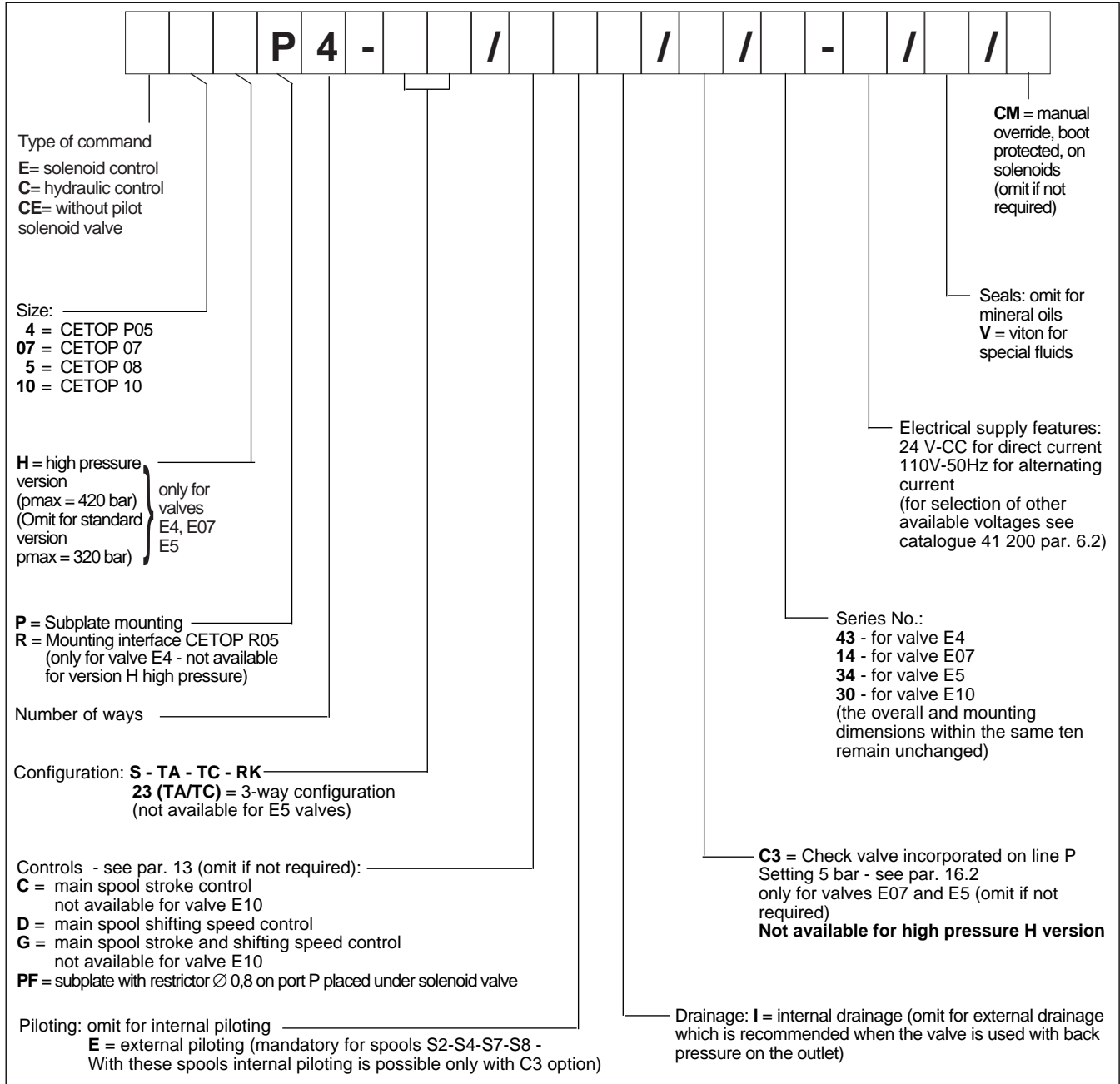

Piloting must always be external for valves with the **C*P4** type hydraulic control valve (available on request).

2 - HYDRAULIC FLUIDS

Use mineral oil-based hydraulic fluids, with the addition of suitable anti-frothing and anti-oxidising agents.

For the use of other fluid types (water glycol, phosphate esters and others), please consult our technical department.

Using fluids at temperatures higher than 70°C causes a faster degrading of the fluid's characteristics and of the seals. The fluid must be preserved in its physical and chemical characteristics.



3 - CONFIGURATIONS

Symbols are referred to the solenoid valve **E***. For the hydraulic control version **C*** please verify the connection scheme (see par. 12.2).

Type **S**: (see note 1)

3 positions with spring centering

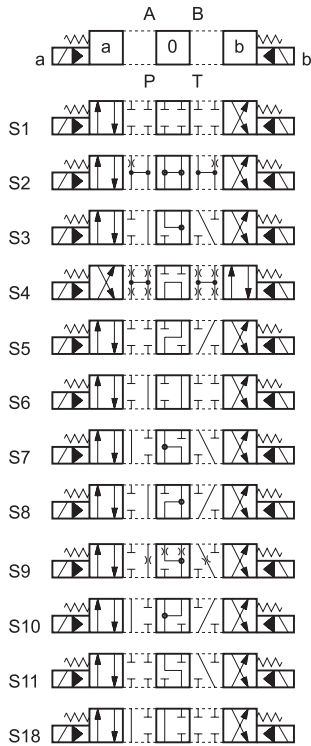

Type ***TA**: (see note 1)

2 positions (central + external) with spring centering

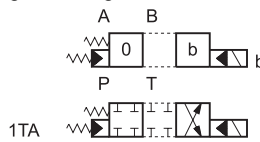

Type **TA**: (see note 1)

2 external positions with return spring

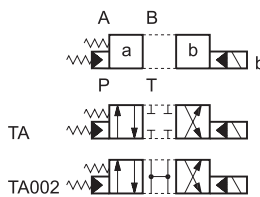

Type **23 (TA/TC)**: (see note 2)

3-way, 2 external positions with return spring

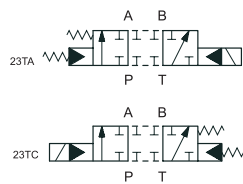

Type ***TC**: (see note 1)

2 positions (central + external) with spring centering

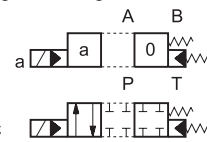

Type **TC**: (see note 1)

2 external positions with return spring

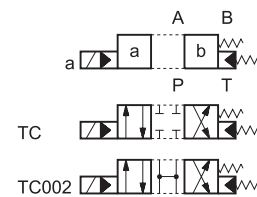

Type **RK**:

2 positions with mechanical detent on pilot valve

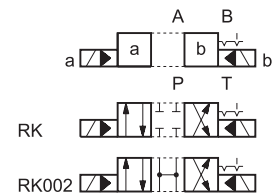

Besides the diagrams shown, which are the most frequently used, other special versions are available: consult our technical department for their identification, feasibility and operating limits.

4 - PERFORMANCE CHARACTERISTICS

PRESSURES [bar]	E4 - E07 - E5		E10	
	MIN.	MAX.	MIN.	MAX.
Piloting pressure	5	210 *	10	210
Pressure on line T with internal drainage	-	140	-	140
Pressure on line T with external drainage	-	250	-	210

Note 1 - The E10 valve is available only in the configurations S1 - S2 - S3 - S4 - S9 - TA - TC - RK

Note 2 - The "23 (TA/TC)" configuration is not available for E5 valves

* For the H execution maximum piloting pressure is 350 bar

MAXIMUM FLOW RATES [l/min]	E4		E07		E5	
	PRESSURES					
Spool type	210 bar	320 bar	210 bar	320 bar	210 bar	320 bar
S4, S7, S8	120	100	250	200	500	450
All other spools	150	120	300	250	600	500

MAXIMUM FLOW RATES [l/min]	E10	
	PRESSURE	
Type of spool	210 bar	350 bar
S2, S4	850	650
S1, S3, S9, TA, TC, RK	1000	750



5 - PRESSURE DROPS Δp -Q (values obtained with viscosity 36 cSt at 50 °C)

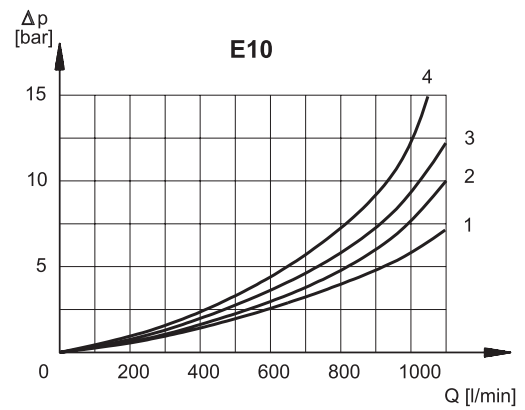
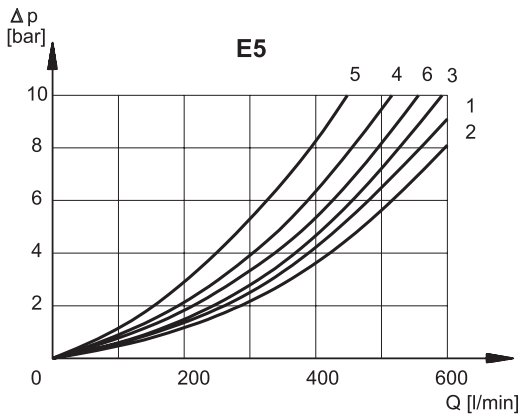
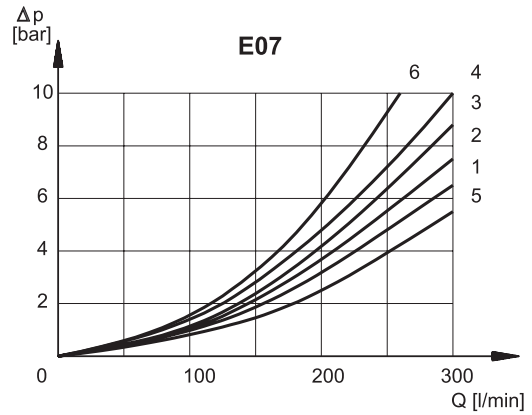
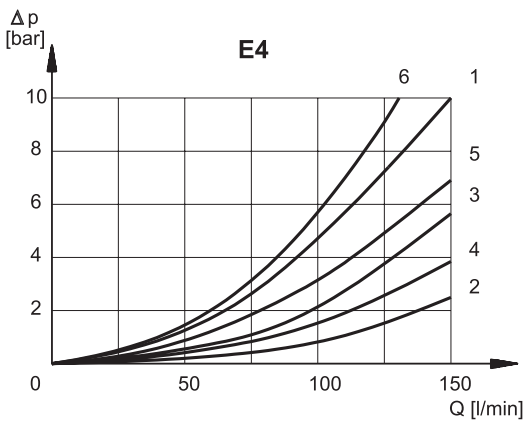

SPOOL TYPE	SPOOL POSITION	E4				
		CONNECTIONS				
		P → A	P → B	A → T	B → T	P → T
S1	Energized	1	1	2	3	
S2	De-energized					6*
	Energized	5	5	2	4	
S3	De-energized			1•	1°	
	Energized	1	1	2	4	
S4	De-energized					6
	Energized	6	6	3	5	
S5	De-energized		1			
	Energized	1	5	2	3	
S6	De-energized				1	
	Energized	1	1	2	4	
S7	De-energized					6°
	Energized	6	6	3	5	
S8	De-energized					6•
	Energized	6	6	3	5	
S9	Energized	1	1	2	2	
S10	De-energized	1•	1°			
	Energized	5	5	2	3	
S11	De-energized			1		
	Energized	1	1	2	3	
S18	De-energized	5				
	Energized	5	1	2	3	
TA	De-energized					
	Energized	1	1	4	3	
RK	Energized	1	1	4	3	

SPOOL TYPE	SPOOL POSITION	E07				
		CONNECTIONS				
		P → A	P → B	A → T	B → T	P → T
S1	Energized	1	1	2	3	
S2	De-energized					6*
	Energized	5	5	1	2	
S3	De-energized			4•	4°	
	Energized	1	1	1	2	
S4	De-energized					6
	Energized	6	6	3	4	
S5	De-energized		4			
	Energized	1	5	2	3	
S6	De-energized				4	
	Energized	1	1	2	2	
S7	De-energized					6°
	Energized	6	6	3	4	
S8	De-energized					6•
	Energized	6	6	4	3	
S9	Energized	1	1	2	3	
S10	De-energized	4•	4°			
	Energized	5	5	2	3	
S11	De-energized			3		
	Energized	1	1	1	3	
S18	De-energized	4				
	Energized	5	1	2	3	
TA	De-energized					
	Energized	1	1	2	3	
RK	Energized	1	1	2	3	

SPOOL TYPE	SPOOL POSITION	E5				
		CONNECTIONS				
		P → A	P → B	A → T	B → T	P → T
S1	Energized	1	1	2	3	
S2	De-energized					6*
	Energized	2	2	1	2	
S3	De-energized			4•	4°	
	Energized	1	1	1	2	
S4	De-energized					5
	Energized	6	6	3	4	
S5	De-energized		4			
	Energized	1	2	2	3	
S6	De-energized				4	
	Energized	1	1	2	2	
S7	De-energized					5°
	Energized	6	6	3	4	
S8	De-energized					5•
	Energized	6	6	4	3	
S9	Energized	1	1	2	3	
S10	De-energized	4•	4°			
	Energized	2	2	2	3	
S11	De-energized			3		
	Energized	1	1	1	3	
S18	De-energized	4				
	Energized	2	1	2	3	
TA	De-energized					
	Energized	1	1	2	3	
RK	Energized	1	1	2	3	

SPOOL TYPE	SPOOL POSITION	E10				
		CONNECTIONS				
		P → A	P → B	A → T	B → T	P → T
S1	Energized	1	1	1	1	
S2	De-energized					3*
	Energized	4	4	4	4	
S3	De-energized					
	Energized	1	1	4	4	
S4	De-energized					
	Energized	2	2	2	2	4
S5	De-energized					
	Energized					
S6	De-energized					
	Energized					
S7	De-energized					
	Energized					
S8	De-energized					
	Energized					
S9	Energized	1	1	1	1	
S10	De-energized					
	Energized					
S11	De-energized					
	Energized					
S18	De-energized					
	Energized					
TA	De-energized	1	1	1	1	
	Energized					
RK	Energized	1	1	1	1	

* A-B blocked • B blocked ° A blocked



6 - PILOTING AND DRAINAGE

The E*P4 valves are available with piloting and drainage, both internal and external.

The version with external drainage allows for a higher back pressure on the outlet.

TYPE OF VALVE		Plug assembly	
		X	Y
E*P4-**	INTERNAL PILOT AND EXTERNAL DRAIN	NO	YES
E*P4-**/I	INTERNAL PILOT AND INTERNAL DRAIN	NO	NO
E*P4-**/E	EXTERNAL PILOT AND EXTERNAL DRAIN	YES	YES
E*P4-**/EI	EXTERNAL PILOT AND INTERNAL DRAIN	YES	NO

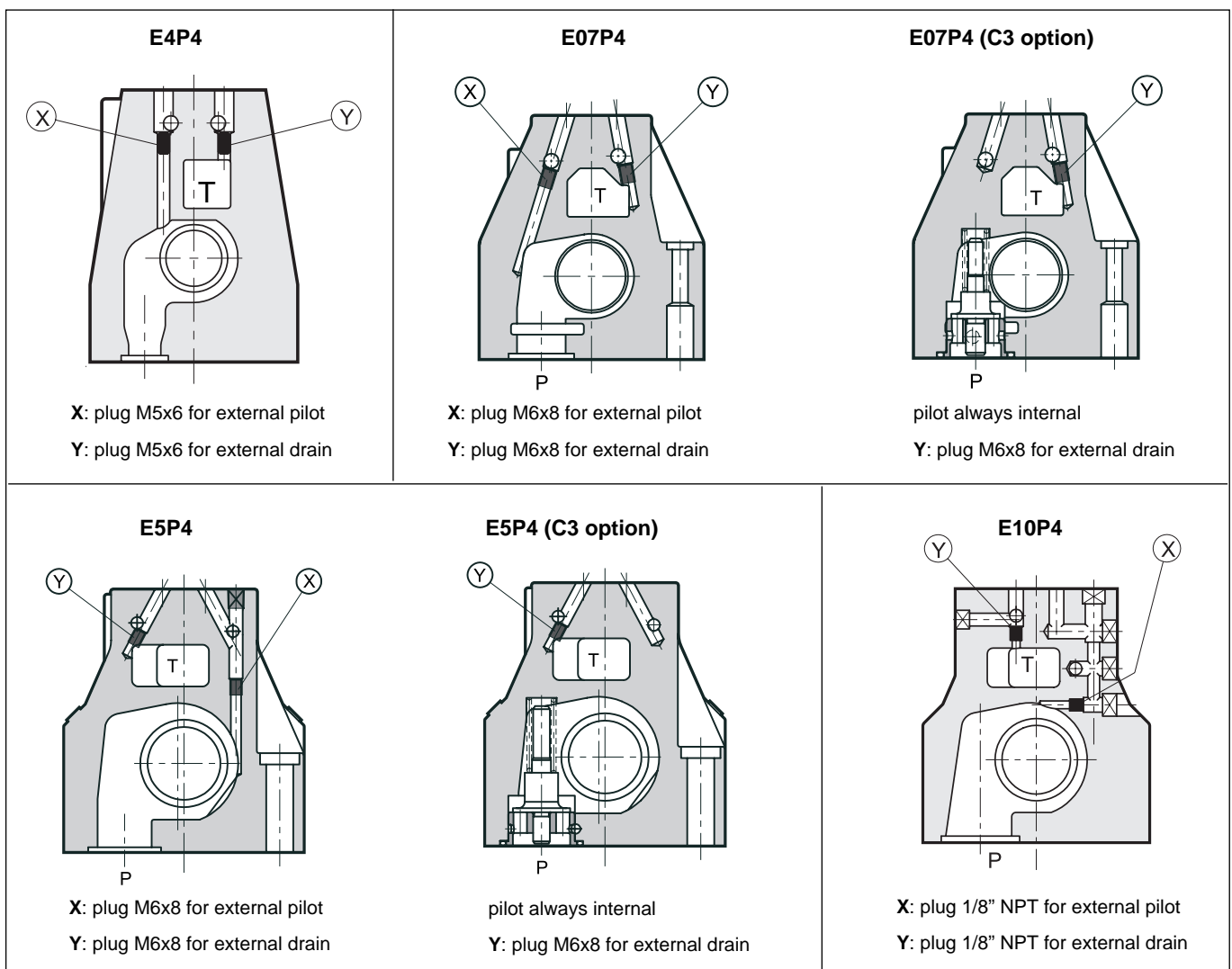



7 - ELECTRICAL FEATURES

7.1 Solenoids

These are essentially made up of two parts: tube and coil. The tube is threaded onto the valve body and includes the armature that moves immersed in oil, without wear. The inner part, in contact with the oil in the return line, ensures heat dissipation.

The tubes for alternating current supply are different than those for direct current and are recognizable by the letter "A" stamped on the rear, the manual override side.

The coil is fastened to the tube by a threaded nut, and can be turned 360° on its axis, compatible with the available space.

The interchangeability of coils of different voltages is allowed within the same type of supply current; alternating or direct (AC or DC / CCR). The CM option is necessary for use in tropical climates.

VOLTAGE SUPPLY FLUCTUATION	± 10% Vnom	
MAX. SWITCH ON FREQUENCY E4 - E07 E5 E10	10.000 ins/hr 8.000 ins/hr 6.000 ins/hr	
DUTY CYCLE	100%	
ELECTROMAGNETIC COMPATIBILITY (EMC) EMISSIONS (see note 4) EN 50081-1 IMMUNITIES EN 50082-2	in compliance with 89/336 EEC	
LOW VOLTAGE	in compliance with 73/23/EEC 96/68/EEC	
Class of protection according to IEC 144 Atmospheric agents Coil insulation Impregnation	IP 65 class H class F	

Note 4: In order to further reduce the emissions, use of type H connectors (for DC or AC supply) is recommended. These prevent voltage peaks on opening of the coil supply electrical circuit (see par. 15)

7.2 Available voltages

See catalogue 41 200 par. 6.2.

7.3 Current and power consumption

See catalogue 41 200 par. 6.3.

7.4 Switching times

The values indicated refer to a solenoid valve operating with piloting pressure =100 bar, with mineral oil at a temperature of 50°C, a viscosity of 36 cSt and with PA and BT connections.

The switch on times are obtained at the time the spool switches over. The switch off times are measured at the time pressure variation occurs on the line.

E4				
TIMES (± 10%) [ms]	ENERGIZING		DE-ENERGIZING	
	2 Pos.	3 Pos.	2 Pos.	3 Pos.
AC solenoid	50	40	70	50
DC solenoid	70	55	70	50

E07				
TIMES (± 10%) [ms]	ENERGIZING		DE-ENERGIZING	
	2 Pos.	3 Pos.	2 Pos.	3 Pos.
AC solenoid	60	40	80	60
DC solenoid	70	50	80	60

E5				
TIMES (± 10%) [ms]	ENERGIZING		DE-ENERGIZING	
	2 Pos.	3 Pos.	2 Pos.	3 Pos.
AC solenoid	60	45	90	60
DC solenoid	75	55	90	60

E10				
TIMES (± 10%) [ms]	ENERGIZING		DE-ENERGIZING	
	2 Pos.	3 Pos.	2 Pos.	3 Pos.
AC solenoid	90	45	50	50
DC solenoid	130	60	80	75



8 - E4 OVERALL AND MOUNTING DIMENSIONS

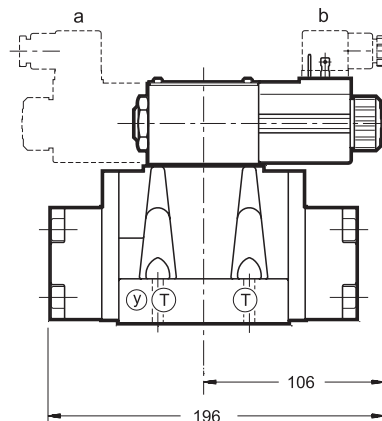
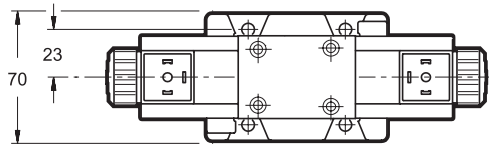
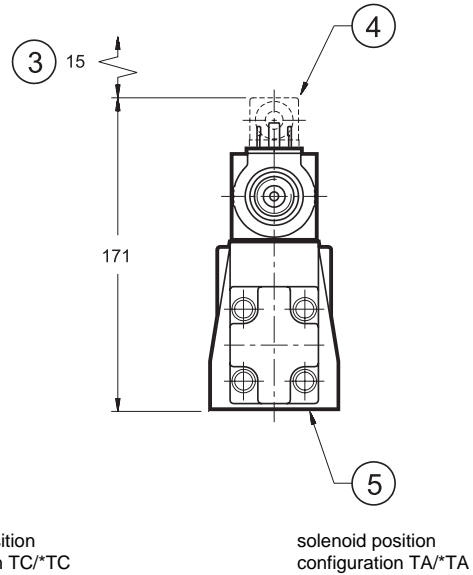
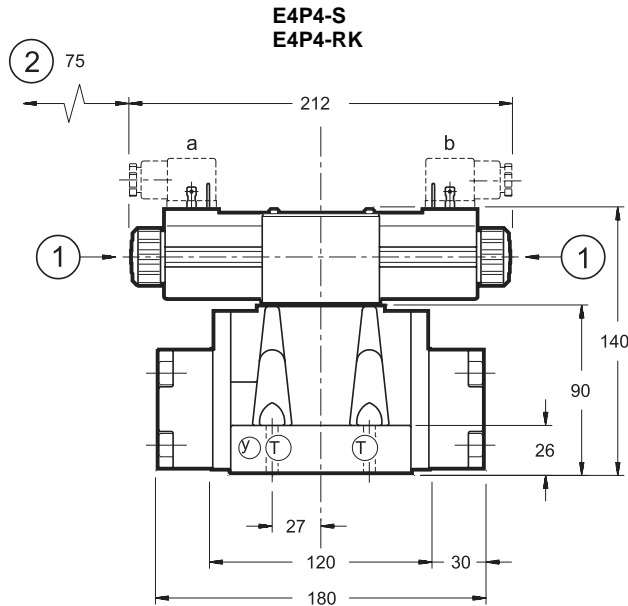

MOUNTING SURFACE (STANDARD)

CETOP 4.2-4 P05-320

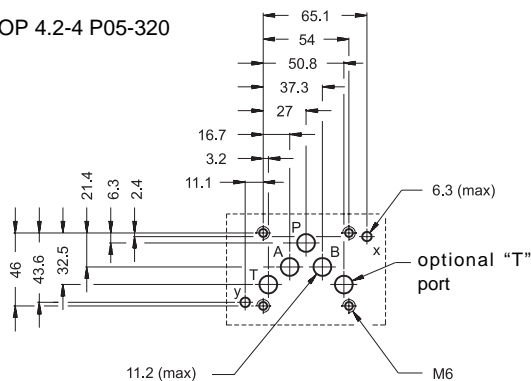

Valves with CETOP R05 mounting interface are available upon request. See par. 1 for their identification.

CETOP 4.2-4 R05-320
ISO/CD 4401-05

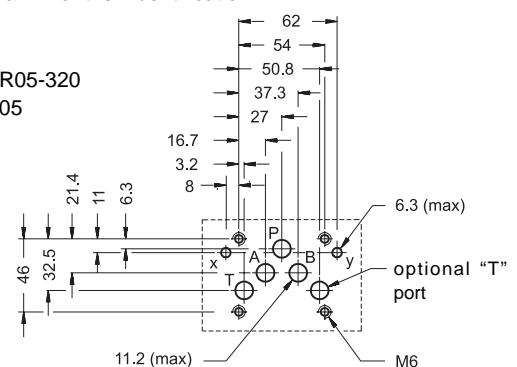

dimensions in mm

Fastening of single valve: 4 bolts M6x35 (see par. 17, Note 5)	1	Manual override
Tightening torque: 8 Nm (bolts A 8.8) 14 Nm (bolts A 12.9)	2	Coil removal space
Threads of mounting holes: M6x10	3	Connector removal space
Sealing rings: 5 OR type 2050	4	Electric connector to be ordered separately (see cat.49 000)
2 OR type 2037	5	Mounting surface with sealing rings



9 - E07 OVERALL AND MOUNTING DIMENSIONS

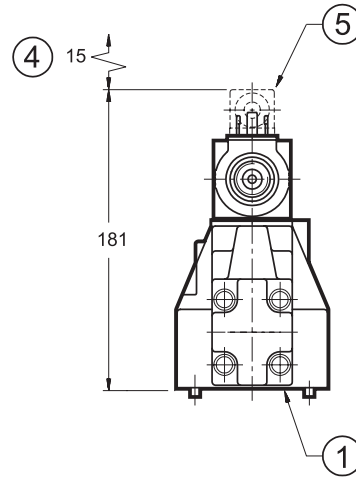
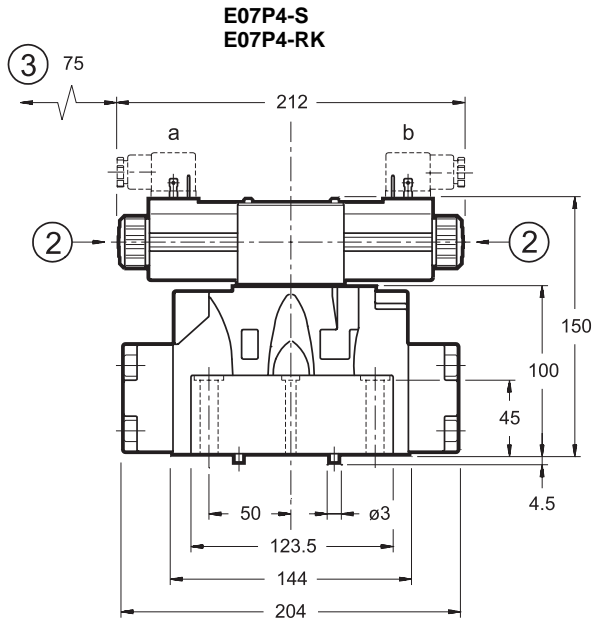

solenoid position
configuration TC/*TC

solenoid position
configuration TA/*TA

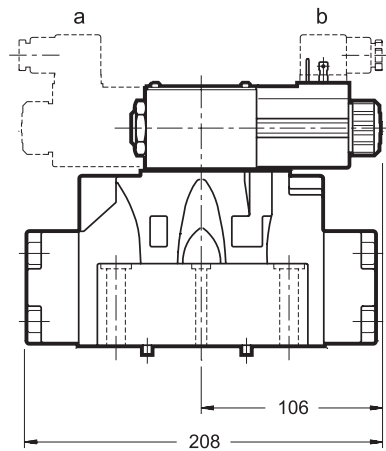
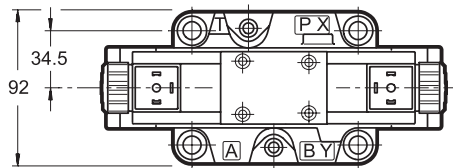

WORKING SURFACE

CETOP 4.2-4-07-320

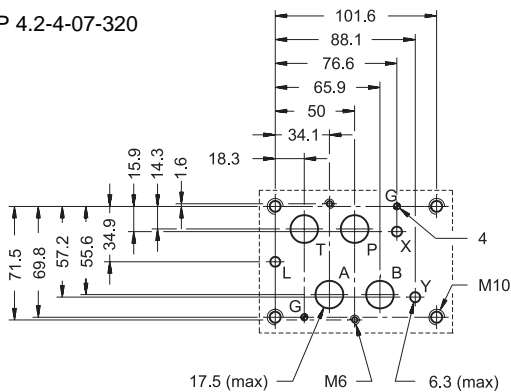

dimensions in mm

Single valve fastening:	4 bolts M10x60 (see par.17, Note 5) 2 bolts M6x60
Tightening torque	M10x60 : 40 Nm (bolts A 8.8) 67 Nm (bolts A 12.9) M6x60 : 8 Nm (bolts A 8.8) 14 Nm (bolts A 12.9)
Threads of mounting holes:	M6x18; M10x18
Sealing rings:	4 OR type 130 2 OR type 2043

1	Mounting surface with sealing rings
2	Manual override
3	Coil removal space
4	Electric connector to be ordered separately (see cat.49 000)
5	Coil with 360° possible orientation



10 - E5 OVERALL AND MOUNTING DIMENSIONS

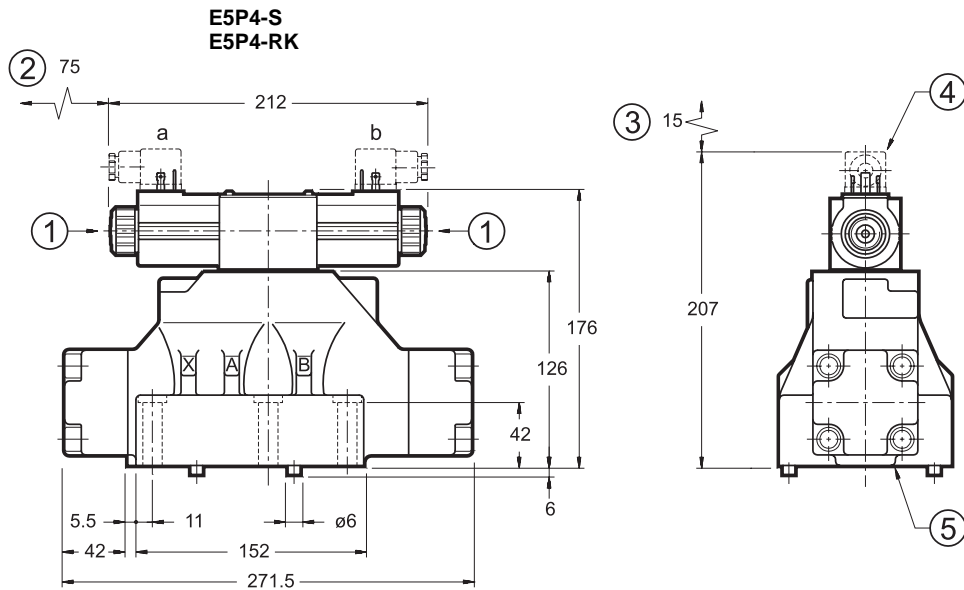

solenoid position
configuration TC/*TC

solenoid position
configuration TA/*TA

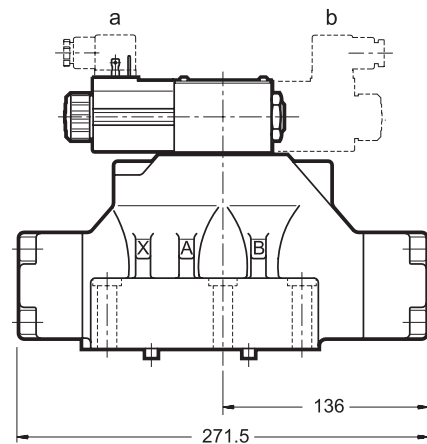
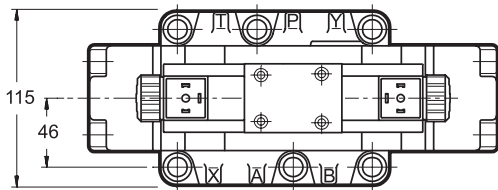

MOUNTING SURFACE

CETOP 4.2-4-08-320

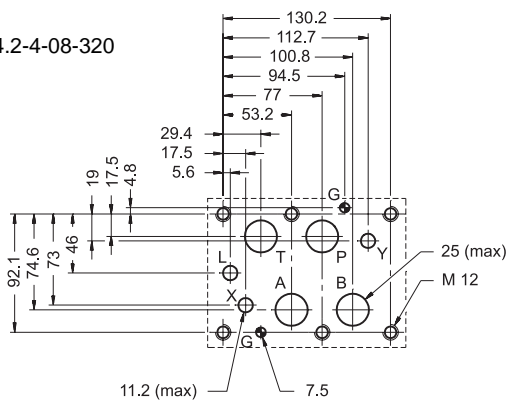

dimensions in mm

Fastening of single valve: 6 bolts M12x60 (see par. 17, Note 5)	1	Manual override
Tightening torque: 69 Nm (bolts A 8.8) 115 Nm (bolts A 12.9)	2	Coil removal space
Threads of mounting holes: M12x20	3	Connector removal space
Sealing rings: 4 OR type 3118 2 OR type 3081	4	Electric connector to be ordered separately (see cat.49 000)
	5	Mounting surface with sealing rings



11 - E10 OVERALL AND MOUNTING DIMENSIONS

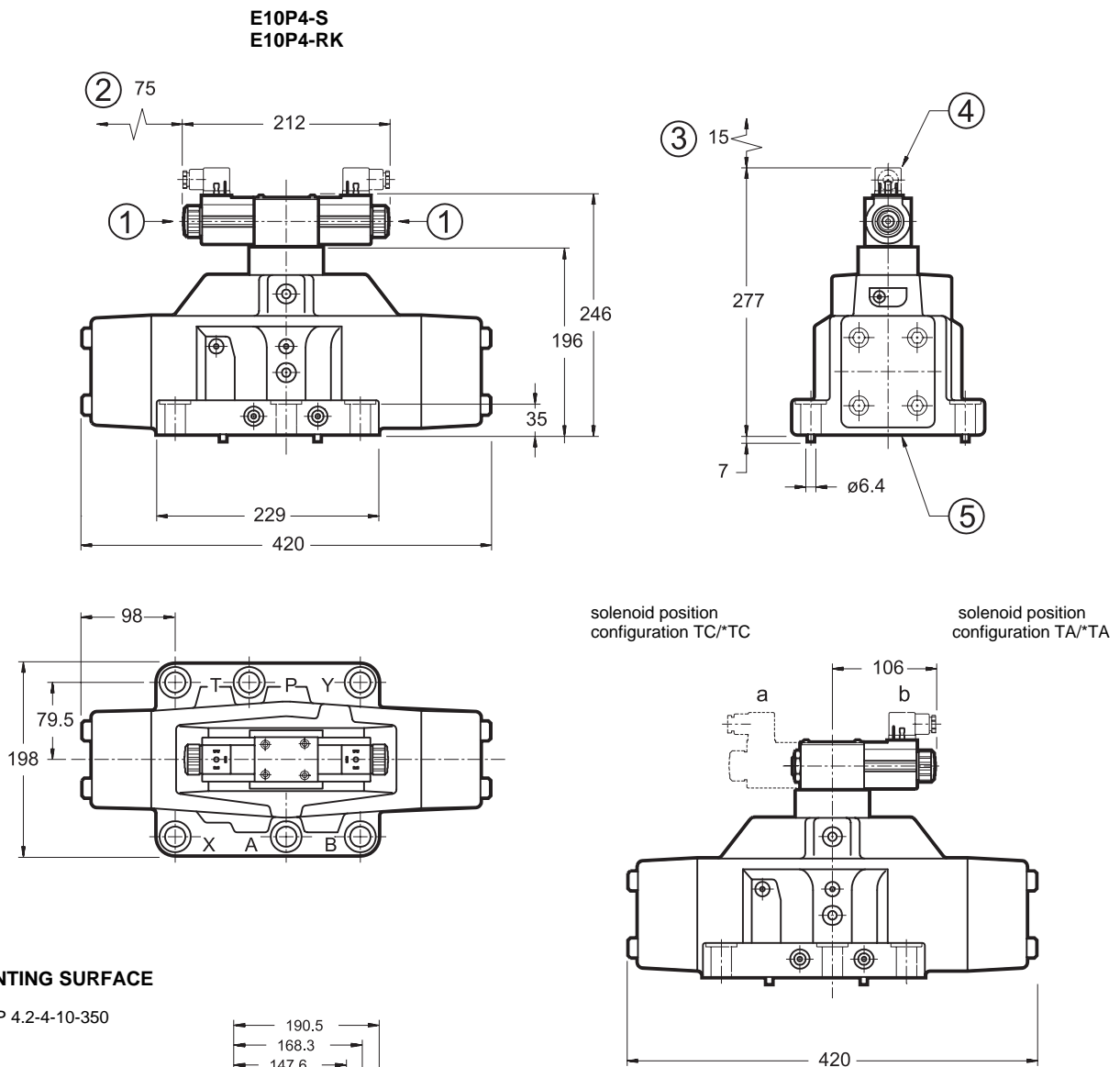

MOUNTING SURFACE

CETOP 4.2-4-10-350

dimensions in mm

Single valve fastening: 6 bolts	M20x70
Tightening torque:	285 Nm
Threads of mounting holes:	M20x40
Sealing rings:	4 OR type 4150 2 OR type 4075

1	Manual override
2	Coil removal space
3	Connector removal space
4	Electric connector to be ordered separately (see cat.49 000)
5	Mounting surface with sealing rings



12 - TYPE OF COMMAND

12.1 - Solenoid control: E*P4

The valve is supplied with a pilot solenoid valve CETOP 03, type MD1D.

12.2 - Hydraulic control: C*P4

The valve is supplied with a cross-connection top cover. X and Y connections are used for the hydraulic control of the valve.

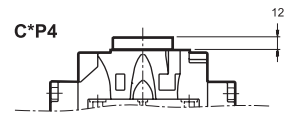
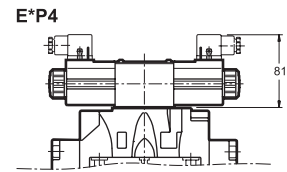
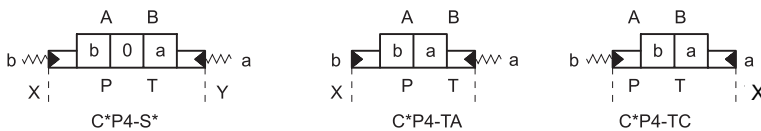

12.3 - Execution without pilot solenoid valve: CE*P4

It is a pilot operated valve, solenoid controlled, supplied without pilot solenoid valve (CETOP 03) to be installed by the user directly.

13 - CONTROLS

13.1 Control of the main spool stroke: C

(Not available for valve E10)

It is possible to introduce special stroke controls in the heads of the hydropiloted valve so as to vary the maximum spool clearance opening.

This solution allows control of the flow rate from the pump to the actuator and from the actuator to the outlet, obtaining a double adjustable control on the actuator. Add the letter **C** to the identification code to request this device (see par. 1).

13.2 Control of the main spool shifting speed: D

By placing a MERS type double flow control valve between the pilot solenoid valve and the hydropiloted valve, the piloted flow rate can be controlled and therefore the changeover smoothness can be varied. Add the letter **D** to the identification code to request this device (see par. 1).

13.3 Control of the main spool stroke and shifting speed: G

(Not available for valve E10)

It is possible to have the valve fitted with both the spool stroke device and the piloting flow rate control device. Add the letter **G** to the identification code to request this solution (see par. 1).

E*P4-S*/C

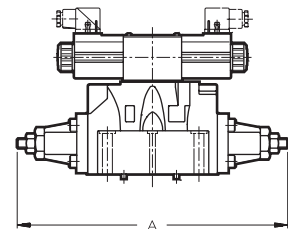

E*P4-S*/D

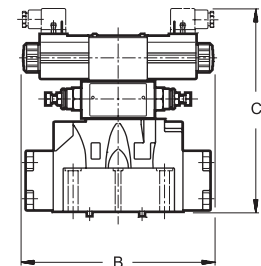

E*P4-S*/G

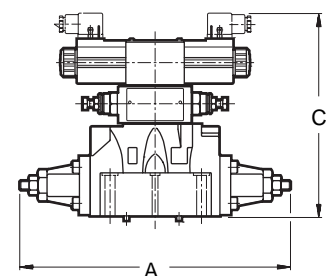

	E4	E07	E5	E10
A	280	320	415	—
B	212	212	272	420
C	211	221	247	317

14 - MANUAL OVERRIDE, BOOT PROTECTED: CM

Whenever the solenoid valve installation may involve exposure to atmospheric agents or use in tropical climates, the manual override, boot protection is recommended. Add the suffix **CM** to request this device (see par. 1).

VERSION /CM

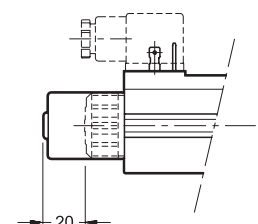



15 - ELECTRIC CONNECTORS

The solenoid valves are never supplied with connector.
 Connectors must be ordered separately.
 For the identification of the connector type to be ordered, please see catalogue 49 000.

16 - SPECIAL CONFIGURATIONS

16.1 - Solenoid valves with special spools

(Not available for valve E10)

Besides the standard configurations (see table 2), Duplomatic can develop, on request, connection diagrams with special spools for a wide range of applications: consult our technical department for their identification, feasibility and operating limits.

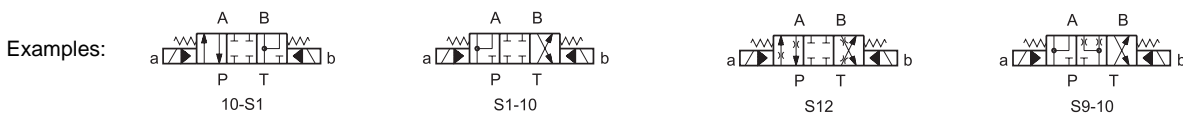

16.2 - Check valve incorporated on line P: C3

(Available only for valves E07 - E5)

Valves E07 and E5 are available upon request with check valve incorporated on line P. This is particularly useful to obtain the necessary piloting pressure when the control valve, in the rest position, has line P connected to the T outlet. The cracking pressure is 5 bar. Add **C3** to the identification code for this request (see par. 1).

C3 version is available only with internal pilot.

VERSION /C3

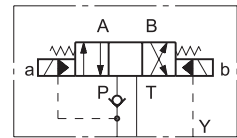

17 - INSTALLATION

Note 5: Use of class 12.9 fastening screws is recommended for valves E4, E07, E5 in version H (high pressure).

Configurations with centering and recall springs can be mounted in any position; type RK valves - without springs and with mechanical detent - must be mounted with the longitudinal axis horizontal. Valve fastening takes place by means of screws or tie rods, laying the valve on a lapped surface, with values of planarity and smoothness that are equal to or better than those indicated in the drawing. If the minimum values of planarity or smoothness are not met, fluid leakages between valve and mounting surface can easily occur.

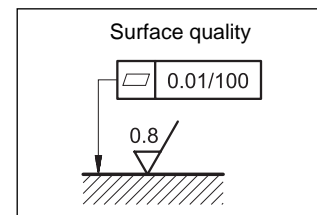

18 - SUBPLATES (see catalogue 51 000)

	E4	E07	E5
Type with rear ports	PME4-AI5G	PME07-AI6G	PME5-AI8G
Type with side ports	PME4-AL5G	PME07-AL6G	PME5-AL8G
P, T, A, B, port dimensions	3/4"	1" BSP	1 1/2" BSP
X, Y port dimensions	1/4" BSP	1/4" BSP	1/4" BSP

	<p>DIPLOMATIC OLEODINAMICA SpA 20025 LEGNANO (MI) - P.le Bozzi, 1 / Via Edison Tel. 0331/472111-472236 - Fax 0331/548328</p>
--	---